

Sanitary Ultrasonic Level Sensor UL-SAN

2-wire loop-powered | 4-20 mA | HART



Overview

The UL-SAN ultrasonic level sensor is the ideal solution for hygienic liquid, slurry or solids level measurement with high reliability and no maintenance requirements. The sensor is designed with a 316L stainless steel transducer face and tri-clamp mounting.

Operation

An ultrasonic pulse is transmitted from the sensor. The pulse travels to the surface being monitored and is reflected off the surface back to the sensor. The time-of-flight is divided by 2, corrected with temperature and converted to an output signal directly proportional to the material level.

The sensor has feedback with the environment and automatically adjusts the transmit power and receiver sensitivity to match the current conditions. With self-adjusting technology, false echoes are eliminated.



Benefits

- Surface finish exposed to process exceeds a No.4/dairy finish (~18 micro inches)
- Steam cleaning / CIP for 30 min. with high temp. and pressure option (up to 130°C / 266°F and 5 bar / 72.5 PSI)
- Maintenance-free due to self-cleaning (no build-up on transducer face) and non-contact operation
- Accurate and reliable measurements with ABM self-adjusting technology, false echoes eliminated
- Plug-and-play installation with simple push-button calibration

Features

- Measuring range up to 30 ft (9.1 m)
- Non-contact continuous measurements
- SS316L transducer face with 1.5" or 2" ferrule
- Built-in temperature compensation
- 2-wire loop-powered operation
- 4-20 mA / 20-4 mA output standard
- HART 7 communication with calibration, diagnostics and data logging software
- Optional remote monitoring and 24/7 support
- Ingress protection class IP68 (NEMA 6)

Applications

Sanitary / hygienic level measurement for:

- Food and beverage
- Pharmaceutical
- Water



SS316L surface exposed to process

Technical Specifications

Range Code	Range	Frequency	Beam Angle	Resolution
148	0.4 - 9 ft (0.12 - 2.7 m)	148 KHz	12°	0.04" (0.98 mm)
081	0.6 - 16 ft (0.18 - 4.9 m)	81 KHz	12°	0.07" (1.8 mm)
080	0.7 - 20 ft (0.21 - 6.1 m)	80 KHz	12°	0.088" (2.2 mm)
070	0.8 - 30 ft (0.24 - 9.1 m)	70 KHz	12°	0.13" (3.4 mm)

Operational	
Accuracy	+/- 0.10 % of maximum range (in lab using 4-20 mA current output) +/- 0.25 % of maximum range (typical in field)
Response Time	2 - 3 echoes / second standard (6 echoes / second standard with less damping) 10 - 30 echoes / second fast protocol (if required)
Beam Angle	10 -12° at -3 dB
Loss of Echo	Hold 1 minute, 22 mA or 2 mA output
Temperature Compensation	In transducer
Calibration	Push-button or programmable via HART 7 communication port
Diagnostics	Echo Profile via communications port

Environmental	
Ambient Temperature	-40 to 60°C (-40 to 140°F)
Process Pressure	≤ 2 Bar (29 psi) standard ≤ 5 Bar (72.5 psi) high temperature and pressure [-HTP]
Process Temperature	-40 to 60°C (-40 to 140°F) standard (no steam cleaning / CIP) -40 to 130°C (-40 to 266°F) high temperature and pressure [-HTP]. (for 30 minutes of steam cleaning / CIP. Remove sensor for longer cleaning cycles, recommended. Not for continuous operation)
Installation Category	Class II

Electrical	
Power	12 to 30 VDC , 0.025 A max @ 24 VDC
Output	4-20 mA output 6.1 uA resolution Optional communication with HART 7

Mechanical	
Conduit Entry	½" NPT Hole
Enclosure Material	PVC standard. Aluminum-94V0 or SS316L optional
Transducer Material*	SS316L face with PVC ferrule standard SS316L face and ferrule high temperature and pressure [-HTP]
Ingress Protection	NEMA 6 (IP68)

* Surface finish exposed to process exceeds a No.4/dairy finish (~18 micro inches)

Approvals	
CE	IEC 61010-1:90 + A1:92 +A2:95
FM (USA)*	FM3810 (2005): Electrical Electronic Test, Measuring and Process Control Equipment
	ANSI/NEMA 250 (1991): Enclosures for Electrical Equipment
FM (CAN)*	CSA C22.2 No. 1010.1 (2004) Safety Requirements for Electrical Equipment for Measurement, Control and Laboratory Use. Part 1: General Requirements
	CSA C22.2 No. 94 (2011) Special Purpose Enclosures

* For sensor models with aluminum or stainless steel enclosures only.

Dimensions and Mounting

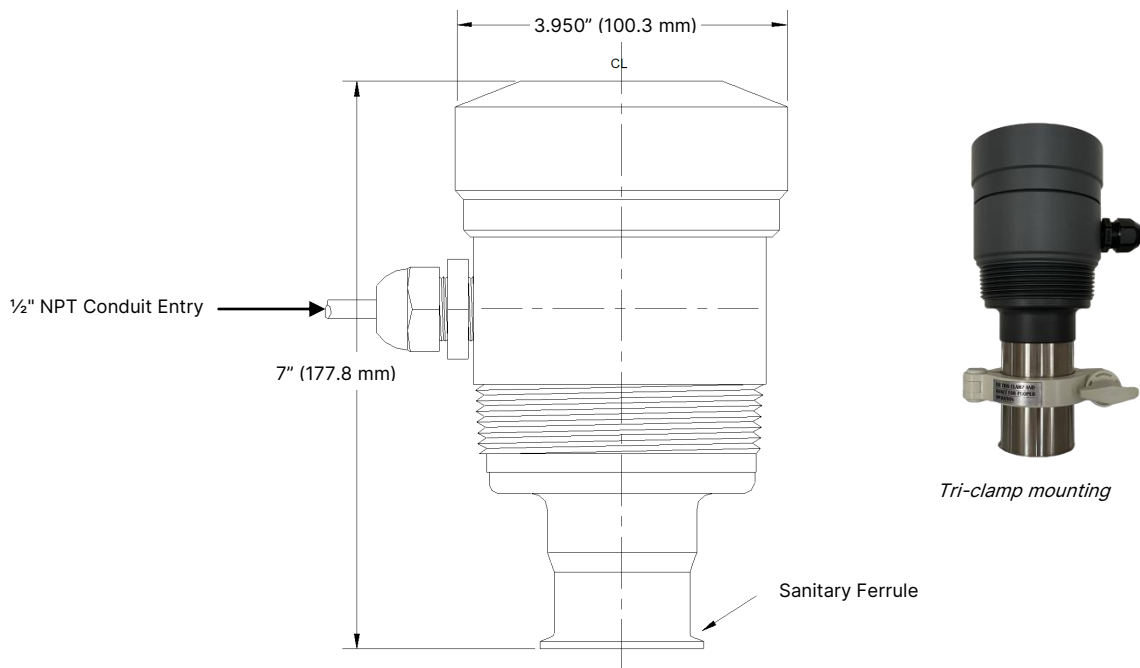

Range Code	Mounting Ferrule	1.5" Ferrule O.D.	2" Ferrule O.D.
148	1.5" (38.1 mm) / 2.0" (50.8 mm)	1.9" (48.3 mm)	2.5" (63.5 mm)
081	1.5" (38.1 mm) / 2.0" (50.8 mm)	1.9" (48.3 mm)	2.5" (63.5 mm)
080	2.0" (50.8 mm)	N/A	2.5" (63.5 mm)
070	2.0" (50.8 mm)	N/A	2.5" (63.5 mm)

Mounting Accessories

Description
Nylon tri-clamp and sanitary silicon gasket for 1.5" ferrule
Nylon tri-clamp and sanitary silicon gasket for 2" ferrule

Model Numbering

View the UL-SAN 2-wire model number table below or configure a product online at:

www.abmsensor.com/product-configurator/.

ABM	XXX -	XXX	XX	XX	XX	XXX
Supply Voltage	-					
12-30 VDC Loop-Powered (2-wire)	200					
Maximum Range		-				
9 ft (2.7 m)		148				
16 ft (4.9 m)		081				
20 ft (6.1 m)		080				
30 ft (9.1 m)		070				
Product Series			-			
Ultrasonic Sensor			UL			
Communication				-		
HART				CH		
Enclosure Material					-	
PVC					PV	
Aluminum					AL	
SS316L					SS	
Transducer Material & Mounting						-
Standard 1.5" Sanitary SS316L Ferrule						S15
Standard 2" Sanitary SS316L Ferrule						S20
High Temperature and Pressure 1.5" Sanitary SS316L Ferrule						S15-HTP
High Temperature and Pressure 2" Sanitary SS316L Ferrule						S20-HTP

Contact

ABM Sensor Technology

730 The Kingsway
Peterborough, ON K9J 6W6 Canada

Phone: +1 (705) 740-2010

Fax: +1 (705) 740-2563

info@abmsensor.com



For more information please visit: www.abmsensor.com

Technical data subject to change without notice.